



Bringing clean air to life:

# AstroPure 2000 Air Cleaner



## Installation and Operation Manual

Manufacturer

**AAF International**

European Headquarters

Odenwaldstrasse 4

D-64646 Heppenheim

Tel: +49 (0)6252 69977-0

Email: [sales.DACH@aafeurope.com](mailto:sales.DACH@aafeurope.com)

For any assistance, please

visit us at [www.aafeurope.com](http://www.aafeurope.com)

to find your local AAF office/dealer

# What's Inside

<b>4</b>	Purpose of this Manual
<b>6</b>	Safety
<b>7</b>	Quick Start Guide (Potentiometer Control)
<b>8</b>	Quick Start Guide (LCD / PLC Control)
<b>9</b>	General information
<b>12</b>	Storage, transport and assembly
<b>13</b>	Commissioning, Operation, Cleaning and Disposal
<b>19</b>	Emergency
<b>20</b>	Drawings and diagrams

<b>21</b>	Spare parts
<b>21</b>	Certificates and Protocols
<b>22</b>	Appendix LCD Control
<b>23</b>	Appendix Potentiometer Control

## Purpose of this Manual



### DANGER:

Imminent danger that leads to severe physical injury or death



### WARNING:

Possibly dangerous situation that could lead to severe physical injury or death

Before you operate the AstroPure air purifier for the first time or if you are entrusted with other work on the AstroPure air purifier, you must read the operating manual.

The operating instructions help you to use the AstroPure air purifier as intended, properly, effectively and safely. Therefore, read the following chapters carefully and carefully. If necessary, always look up facts that are decisive for you.

The operating instructions inform and warn you of residual risks against which a risk reduction through design and protective measures is not or not fully effective.

### Target groups

**Key User:** Keep these instructions and other applicable documents available at the place of use of the system, also for later use.

**User:** encourage you to read and observe these instructions and the applicable documents, especially the safety and warning notices. Observe additional system-related provisions and regulations.

**Qualified maintenance personnel:** Read, observe and follow these instructions and other applicable documents, especially the safety and warning notices.

**Personnel qualification:** A qualified person is understood to mean a person who has successfully completed vocational training. He/She must assess the work that has been assigned and be able to independently recognize and avoid possible dangers based on her professional training and work experience.

Personnel for the **maintenance** and **repair** of **ventilation devices** and **air filters** must be **trained** and **instructed** (for example according to **VDI 6022-4**).

### Delivery documents

The AstroPure air purifier is shipped with an

- installation, operation and maintenance manual,
- AAF HEPA filter test report.

For maintenance instructions the following documents from other supplier are supplied and must also be read and observed:

- Fan: type „E“ or „Z“
- LCD / PLC panel (optional)
- UV-C-Stage (optional)

### Orientation in these operating instructions

These operating instructions contain the following general information symbols that guide you, the reader, through the operating instructions and give you important information.

### Intended Use:

AstroPure air purifiers are designed exclusively to free normal room air from suspended particles and to return the purified air to the room.

AstroPure air purifiers are intended as devices for installation exclusively in commercial and non-commercial interiors.

### Foreseeable misuse:

AstroPure air purifiers must not be used for any other purpose. The following foreseeable misuse is not permitted:

- Extraction from an explosive atmosphere
  - Use as a dust extraction system
  - Use as a smoke extraction system
  - The operation of the AstroPure air purifier with blocked air inlets and outlets
  - Independent remodeling or repair work
  - Operating the AstroPure air purifier without instruction or training
- Any other use case requires written approval from AAF International.



### ATTENTION:

Potentially dangerous situation that could lead to minor physical injuries.



### NOTE:

Situation that can lead to possible property damage to the AstroPure air purifier.

## 1. Safety



**DANGER: ELECTRIC SHOCK**



**DANGER: NOISE**

The unencapsulated fan can generate sound emissions > 70dB (A) (with the aintenance door open). Damage or loss of hearing can result.



**EAR PROTECTIONS**

Have device maintenance and repair carried out by qualified personnel only. Sufficient hearing protection must be worn during maintenance and repair work when the fan is running.



**DANGER: CRUSHING HAZARD**

There is a risk of crushing when opening the maintenance door. This can result in bruising of the extremities. Have device maintenance and repair carried out by qualified personnel only.

**Operation may only be carried out after a instruction and training.**

**Maintenance and repair may only be carried out by qualified personnel.**

**Observe the principles for the safe operation of electrical devices.**

**For maintenance and repair work, the accompanying documents for the supplier components must be observed.**

Hazard potential emanating from the AstroPure Air Cleaner.

### Electric shock:

Electrical supply line can possibly be defective.  
Under no circumstances use devices with a damaged electrical connection cable.

- Check the power cords before use.
- Damaged cables must be replaced immediately.
- Electric cables must never be exposed to water, heat or sharp objects.
- Do not move the device by pulling the power cord.
- Avoid running equipment and vehicles over power lines, or provide adequate protection for them.
- The device should be in the off mode to connect or disconnect the main power supply.
- Internal cabling (fan, control panel, UV-C stage) can be defective.
- Do not continue to operate devices with an internal error and, if possible, disconnect them from the power supply.
- Carry out maintenance and repair work only when the power supply is disconnected and the AstroPure air purifier is switched off.

### Crushing Hazard:

Due to its own weight, there is a risk of crushing when transporting and moving the AstroPure air purifier.

This can result in bruising of the extremities.

The AstroPure air purifier must be moved with an appropriate method to avoid accidental injury or damage of any kind.

Preferred method is to use approved lifting gear and secured against unintentional lowering of the load:

1. protect the forklift forks before lifting
2. lift up slightly the AstroPure unit using the forklift and remove it from the wooden pallet
3. put down the AstroPure unit using the forklift



## 2. Quick Start Guide (Potentiometer Control)

### Quick start guide

- Observe the safety instructions for safe operation
- Ensure a safe stand on smooth, level, stable ground/floor
- Lock the castor wheels
- ON / OFF switch in OFF
- Set the speed controller to the "OFF" position
- Plug in the power plug
- ON / OFF switch ON
- Check serial number for fan type on the Type Plate on the back of the uni  
Serial No. : E11-2020-12345 => "E"-type  
Serial No. : Z11-2020-12345 => "Z"-type
- Rotate speed setting to desired air volume flow according to the table below

Speed Control Set Point	Fan Type E	Fan Type Z
0	0	0
1	0	0
2	300	50
3	600	250
4	950	500
5	1250	750
6	1600	1050
7	1900	1350
8	2200	1650
9	2400	2000
10	2400	2300

### Yellow warning lights light up:

Filters must be changed by qualified personnel

- Note the date of first use
- Note down the operating time
- Observe and document change intervals for filters

### Have the filter change and maintenance carried out by qualified personnel only

### In the event of danger or malfunction:

Pull out the mains plug and have the device serviced by qualified personnel



Observe the protective instructions on the device. Secure the open maintenance door against unintentional closing.



**DANGER: ROTATING DEVICE**

Fast rotating parts of the fan The high-speed impeller of the fan can injure body parts on contact. Have device aintenance and repair carried out by qualified personnel only.



**DANGER: CRUSHING HAZARD**

The device can tip over if lifted (excessively). This can result in bruising of the extremities. Do not tilt the device. Set up the device outside the area of movement of people.



**DANGER: CRUSHING HAZARD**

Optional: The AstroPure air purifier is equipped with an additional UV-C stage. UV-C radiation bears the risk to cause severe damages to the eye and skin. The UV-C stage is not accessible during normal operation.

### 3. Quick Start Guide (LCD / PLC Control)

#### Quick start guide

- Observe the safety instructions for safe operation
- Ensure a safe stand on smooth, level, stable ground
- Lock the castor wheels
- Plug in the power plug
- Switch the ON/OFF switch at the back side of the unit to ON-position
- Press the standby button to turn on the fan 
- To unlock the screen, enter the password "116"
- Adjust volume flow rate to desired level by tapping on + (increase) or – (decrease)

#### Information "Service" on display:

Filters must be changed by qualified personnel

- Note the date of first use
- Note down the operating time
- Observe and document change intervals for filters

**Have the filter change and maintenance carried out by qualified personnel only.**

#### In the event of danger or malfunction:

Pull out the mains plug and have the device serviced by qualified personnel

### 4. General Information

The AstroPure air purifiers are designed to remove particles from normal dry room air, which is returned to the room after cleaning.

The installation conditions are:

- Installation indoors in a dry environment
- Moving and purification of dry indoor air
- Operating temperature range: 0 ° C to 40 ° C
- Air humidity rH. <90%, no condensable humidity
- Not approved for use in an explosive atmosphere
- Filter change as described in the maintenance instructions
- Carry out cleaning, maintenance and repair as specified in the maintenance instructions and in accordance with VDI6022

#### Type label

The Type label of the AstroPure air purifier shows the following characteristics (example below):

AstroPure® Air Purifier				AAF CORPORATION	
Type :	AstroPure 2000 recirc./no UV/ino LCD/ino Carbon			Motor :	1ph EC
Q. flow :	2000	m³/h		Fan Type :	AAF 400
Material :	Galv. Steel			n. max :	1450 1/min
Weight :	150	kg		U :	200-277 VAC
Size :	770x720x1628 mm			I :	1.5 A
Serial No. :	E11-2020-00002			f :	50-60 Hz
Man. Date :	2020-47			P :	500 W
IP :	IP20			SFP, design point :	E:0.513 Z:0.452 kW(m³/s)
				SPL :	24-55 dBA
Part No. : BR00000554   555003777					
					
				Made in Poland CEM AAF	

Image 1 : AstroPure type label

### Technical characteristics

Parameter	Unit	AstroPure - 2000
Nominal flow rate	m <sup>3</sup> /h	2000
Dimensions (WxLxH)	mm	770x720x1628*
Device weight	kg	150*
Min. ambient temperature	°C	0
Max. ambient temperature	°C	40
Allowed rel. humidity level	%	0-90
* depending on execution		
Connection details and power consumption		
Connection details		1PH 230V 50 / 60Hz
Fan	kW	0,5
UV-C stage	W	25
Sound pressure level (SPL) at a distance of 1 m	Db(A)	24-55
SFP	kW/m <sup>3</sup> /s	0,513 (Fan type "E") 0,452 (Fan type "Z")
IP-class		IP20
Maximum recommended pressure drop:		
Pre filter		
RedPleat	Pa	250
RedPleat VF	Pa	250
HEPA filter:		
AstroCel III	Pa	450
MEGACel I	Pa	450

Table 1 : Technical parameter of AstroPure 2000 Air Cleaner

### Accompanying guidelines and documents

The installation and use conditions are:

- AAF pre-filter Technical Data Sheet
- AAF HEPA filter Technical Data Sheet
- AAF Filter change out recommendations
- AAF filter storage recommendations

Technical details of fan and UV-C stage are relevant only to service / repair personnel.  
For the most current versions visit us at [www.aafeurope.com](http://www.aafeurope.com)

### Components

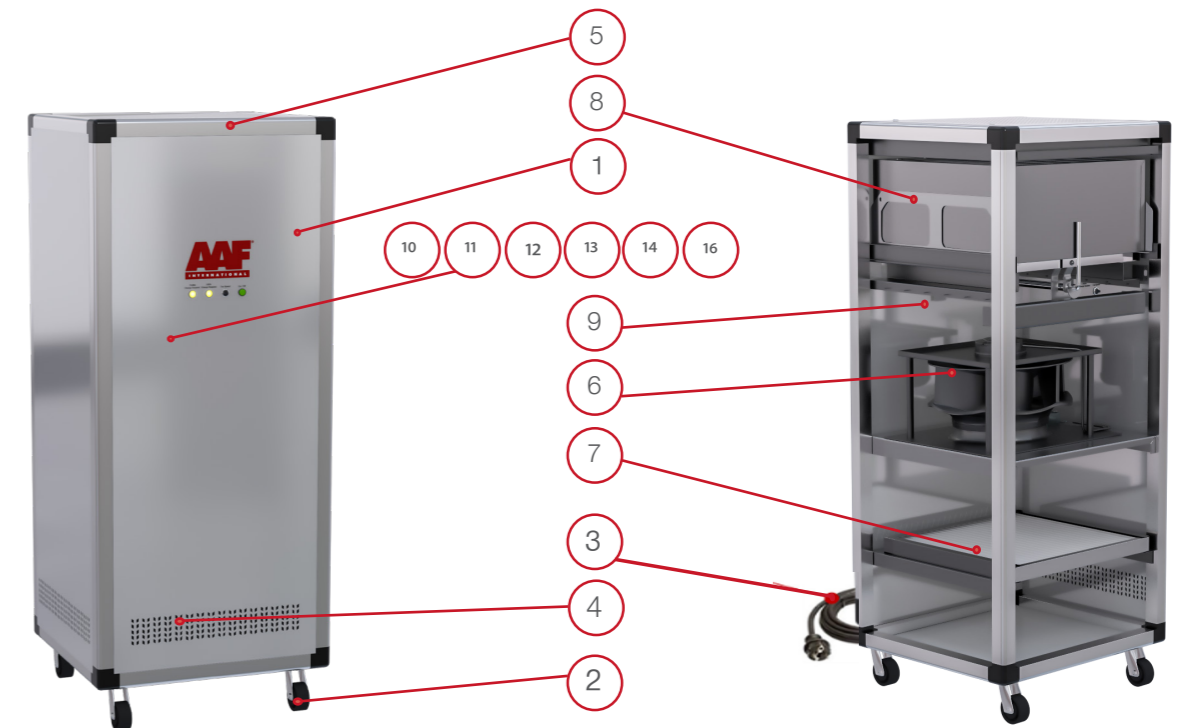

Image 2 AstroPure with Potentiometer Control



Image 3 AstroPure with LCD / PLC Control

- The AstroPure air purifier (1) has the following main components:
- Swivel castors with locking device (2)
- Power plug (3) / LCD/PLC: Power plug with On/OFF switch at the back of the unit
- Air inlet (4)
- Air outlet (5)
- Fan (6)
- Pre-filter (7)
- HEPA filter (8)
- OptionalUV-C stage (9)
- Control panel (10)
- The control unit consists of the following individual parts:
- ON / OFF switch (11)
- Operating status light device ON (12)
- Volume flow controller (13)
- Status display pre-filter (14)
- Status display HEPA filter (15)
- LCD panel (16)

#### Filter and consumables

The AstroPure air purifiers are equipped with the following filter stages:

- Pre-filter
- HEPA filter
- Optional: UV-C stage

#### Decommissioning in the event of maintenance

The device must be switched off and disconnected from the power supply for maintenance and repair.

## 5. Storage, transport and assembly

### Storage

The storage conditions for the AstroPure air purifiers are:

- Storage in a dry, protected environment, if possible in the original packaging.
- Storage temperature range: -30 ° C to 40 ° C

Air humidity rH. <90%, no condensable humidity.

### Unpacking

Remove the securing straps, stretch wrap, and card board packing material from the AstroPure 2000 Air Cleaner. Disposal of the packaging material must obey the local waste disposing regulations.

### Castor rolls

Castor rolls are fastened on the bottom with bolts (M10, M13 wrench).

### Transport

Only move heavy loads with suitable means of transport.

### Installation of Air Inlet and Air Outlet ductwork (optional)

Installation of Air Inlet and Air Outlet ductwork needs to be carried out by qualified personnel only.

### Installation area

The installation surface must be smooth and level and have sufficient load-bearing capacity.



DANGER: CRUSHING  
HAZARD



WEAR SAFETY SHOES



Avoid hard knocks and jerky  
loads. Risk of filter damage.

Secure the load against  
unintentional rolling away.

## 6. Commissioning, Operation, Cleaning and Disposal

### General

In case of any abnormal noises, sounds, and vibrations or in case of no operational sounds (no fan sound), turn the AstroPure Air Cleaner off, disconnect it from the power supply and have the equipment inspected by trained personnel.

**Maintenance work must be carried out by qualified personnel only according to the instructions by AAF as well as the personnel for the maintenance and repair of ventilation devices and air filters must be trained and instructed (e.g. according to VDI 6022-4). Personal protective equipment (gloves, respirator, eye protection) must be worn during maintenance work inside the device and when changing the air filter.**

### Control panel Potentiometer Control

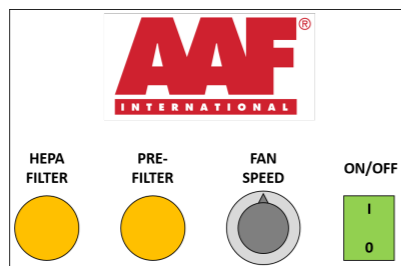

1. Potentiometer Control

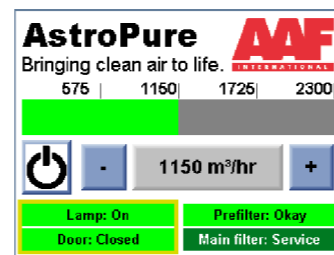

2. LCD / PLC Control

Image 5 AstroPure Control Panel

The control unit consists of the following individual parts:

#### Potentiometer Control:

- ON/OFF switch (11)
- Operating status light device ON (12)
- Volume flow controller (13)
- Status display pre-filter (14)
- Status display HEPA filter (15)

#### LCD / PLC

- ON/OFF switch at the back of the unit (3)
- Touch sensitive display (16)
- Indicators signalling the need for filter servicing

### Initial start-up

The AstroPure air purifiers are delivered ready for use. Perform the following work steps for initial commissioning:

- Remove packaging and dispose of properly in accordance with local waste regulations.
- The AstroPure air purifiers are equipped with four swivel castors for easy manoeuvrability.

- Make sure that all four swivel castors have good contact with the installation surface and, if necessary, enable this by repositioning the device.
- Make sure that the maintenance door of the device is properly closed.
- Make sure that the air inlet and outlet openings are freely accessible and not obstructed or occupied.
- Fix the locking devices of the castors.

### Filters:

The following filter options are installed:

	Type	Style Code
Pre-filter (7)	RedPleat	ISO Coarse 70%
	RedPleat	ISO ePM10 70%
	RedPleat CF	ISO Coarse 65%
HEPA filter (8)	MEGACel I	H14
	ASTROCEL III	H14

### Operation (Potentiometer Control)

- Make sure the ON / OFF switch is in the OFF position.
- Set the volume flow controller / speed controller to a middle position.
- Plug in the power plug.
- Set the ON / OFF switch to ON.

### Set the desired volume flow.

- Keep a sufficient distance from the outflow openings.
- The volume flow can be regulated continuously between minimum (25% maximum volume flow) and maximum volume flow.
- Set the desired volume flow.
- Set the desired volume flow by turning the rotary knob according to set points given in the table "Quick Start Guide (Potentiometer Control)" (page 7).



CRUSHING HAZARD:



WEAR SAFETY SHOES

### Operation (LCD / PLC Control)

- Plug in the power plug
- Set the ON/OFF switch at the back side of the unit to ON.

### Set the desired volume flow.

- Press the standby button to turn on the fan
- To unlock the screen, enter the password "116"
- Volume flow adjustment:
  - Method (1)
    - Press the flow rate bar to set the initial value. The exact desired speed of the fan can be set here.
    - Press the plus and minus button. The respective speed increment is set in the configuration menu.
  - Method (2)
    - Press an area on the flow rate bar. With this option, the speed of the fan is set to one of the 4 parameter values at a time (25% steps).

- Information on display:

Service: filters must be changed by qualified personnel

## AstroPure 2000 LCD

To access the user menu (to unlock the display), the user can press the 'AstroPur' logo or, alternatively, press the lock symbol for 2 seconds.

The user menu password is "116".

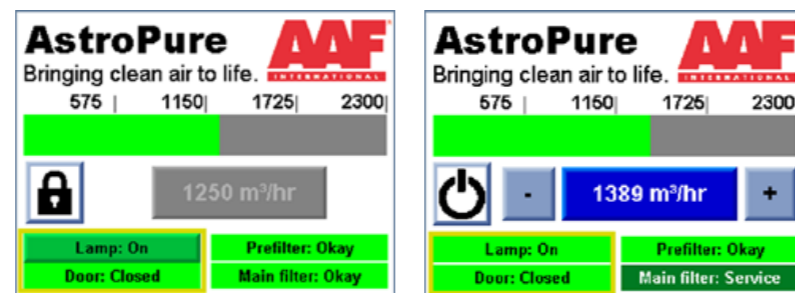

AstroPure 2000 Main menu

### Main User Menu

Press the AstroPure logo for 3 seconds.

The language settings can be modified and system information can be viewed (software version, hardware ID).

After 60 seconds of inactivity, the main screen will automatically 'lock', viz. no changes can be made to any settings, e.g., main standby switch on/off, airflow set point, lamp on/off, etc.

To modify any setting, the screen needs to be unlocked again.

After 60 seconds of inactivity, the main screen will automatically 'lock', viz. no changes can be made to any settings, e.g., main standby switch on/off, airflow set point, lamp on/off, etc.

To modify any setting, the screen needs to be unlocked again.

Software version: ASP101v19

Controller ID #: 14943547

Language: English French German Spanish

Fan operating hours: 3429

Lamp operating hours: 1484

Lock after 60 seconds of inactivity.

return

### Configuration menu, language and system information

Press the AAF-logo field for 5 seconds to enter the configuration menus.

Enter the password "-1101".

The controller's parameters can be changed here.

### Resetting of operating hours

In the configuration menu, these values can be reset by pressing the corresponding button for 5 seconds.

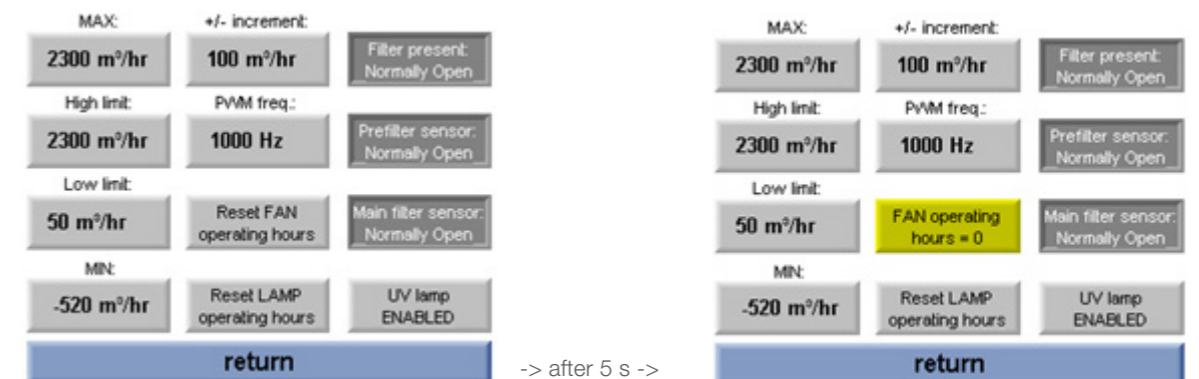

### Appropriate flow rate

To achieve best air cleaning results, the air cleaners flow rate must be adjusted to the individual situation of the designated room.

Following calculation steps provide a basic guide line:

- The volume of the designated room in cubic meters (m³) is calculated by multiplying the room's length \* width \* height in meters:  $V = L * W * H$
- The desired number of room air exchanges per hour (ACH) has to be selected (units: 1 /h). This number is sometimes also referred to as air exchange rate.

When this value is not preset, the following ACH values represent the currently applied recommendations:

- Good ventilation: ACH = 4 1/h
- Excellent ventilation: ACH = 6 1/h
- Purging of rooms: ACH = 10 1/h

The necessary air flow rate is then determined by multiplying the room's volume V with the desired air exchanges per hour.

- Necessary flow rate = V \* ACH

Example:

- A room has the dimensions of (L \* W \* H) = 5 m \* 8 m \* 3 m
- The volume is calculated to 5 m \* 8 m \* 3 m = 120 m<sup>3</sup>.
- The desired air exchange rate is ACH = 4 1/h
- The air cleaner has to deliver 4 1/h \* 120 m<sup>3</sup> = 480 m<sup>3</sup>/h.

The table below serves for guidance.

Parameter	Symbol	Unit	Example 1	Example 2	Example 3	Example 4
Length	L	m	10	10	10	10
Width	W	m	10	10	10	10
Height	H	m	2	2.5	2.5	2.5
Volume	V	m <sup>3</sup>	200	250	250	250
Air exchanges per hour	ACH	1/h	4	4	6	8
Required air volume flow		m <sup>3</sup> /h	800	1.000	1.500	2.000

#### Cleaning of the external surface

Always disconnect the AstoPure Air Cleaner from the power connection when cleaning it.

The surface of the device can be cleaned with common mild soap based household cleaning detergents only.

#### Disposal

Spent filters should be packed in sealed plastic bags individually and disposed off in accordance with local waste regulations.

Decommissioned electric and electronic equipment must be returned to approved collection points in accordance to the local waste regulations.

#### Inspection and maintenance per component

The device components and filters must be checked for function and wear at regular intervals and serviced, at least after the periods specified below or earlier if necessary

Inspection Intervals		
Pre filter:	months	3
HEPA filter:	months	3
UV-C Stage	months	3
Maintenance door	months	6
Moving parts	months	6
Fan section	months	6
Entire unit	months	Prior to each use and very 12 months

Replacement Intervals		
Pre filter:	months	3
Red Pleat	months	6
RedPleat CF	months	6
HEPA Filter		
AstroCel III	months	12
MEGAcel I	months	12
UV-C Stage	hours	9.000

## 7. Emergency:

If possible, disconnect the AstroPure air purifier from the power supply by pulling the plug. If it is not possible to pull out the mains plug safely, the power supply must be interrupted by disconnecting it from the building circuit (safety switch)

#### Fire fighting

In the event of a fire, fight it with extinguishing agents approved for electrical appliances. Dangerous substances escape in the event of fire.

In the event of a fire, do not breathe the fumes and smoke that may be produced. After ensuring that the extinguishing is complete, ensure that the rooms are adequately ventilated.



DANGER:  
Electric shock

## 8. Drawings and diagrams:

The overall dimensions the installation dimensions of the AstroPure 2000 Air Cleaner are:



Image 5 AstroPure 2000 Dimensions

Fan type "E"

AstroPure® Air Puri	
Type :	AstroPure 2000 recirc./no U
Q. flow :	2000 m <sup>3</sup> /h
Material :	Galv. Steel
Weight :	150 kg
Size :	770x720x1628 mm
Serial No. :	E11-2020-12345
Man. Date :	2020-47
IP :	IP20
Part No. :	BR00000554   555003777

Fan type "Z"

AstroPure® Air Puri	
Type :	AstroPure 2000 recirc./no U
Q. flow :	2000 m <sup>3</sup> /h
Material :	Galv. Steel
Weight :	150 kg
Size :	770x720x1628 mm
Serial No. :	Z11-2020-12345
Man. Date :	2020-47
IP :	IP20
Part No. :	BR00000554   555003777

Image 7: type label, serial number and fan type.

### Wiring diagram

The wiring diagram for the AstroPure Air Cleaner can be found in the appendix.

### Serial number and fan type

The AstroPure 2000 is equipped with either fan type "E" or fan type "Z", which can be identified from the unit's serial number (example on the left).

### Fan calibration curves

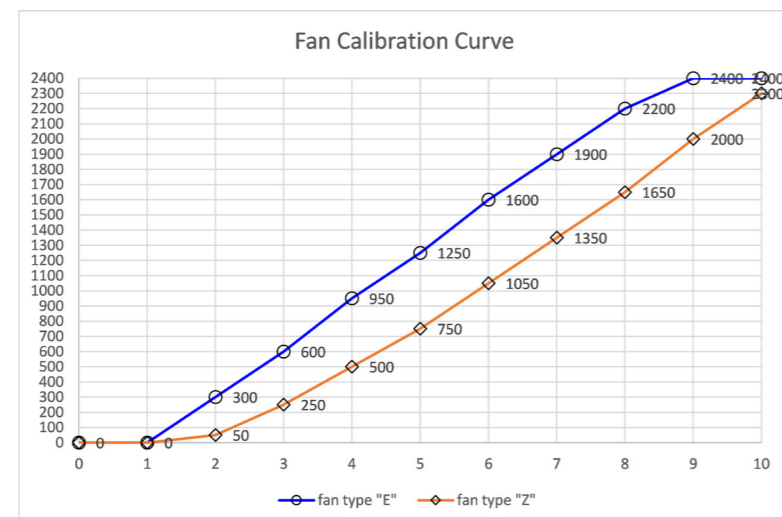

## 9. Spare parts:

The following filter options are to be used when replacing filters:

	Type	Style code	Part number	WxHxL (mm)
Pre-filter (7)	RedPleat	RP-4470-05920592045-CS00Z	555001210 (4531002424)	592 x 592 x 45
	RedPleat	RP-5370-05920592045-CS02Z	555004102 (4151002424)	592 x 592 x 45
	RedPleat CF	RPCF-0465-05920592045-CS0Z	555000951 (4139002424)	592 x 592 x 45
HEPA filter (8)	MEGACel I	MEGA I.eFRM.H14.610x610x292	(295099013)	610 x 610 x 292
	ASTROCEL III	ASTROCEL III AP A39A05C9S2R0	555004088 (1493299990)	610 x 610 x 292
UV-C lamp (9)	PHILLIPS	TUV 25W 1S/25	(BR00000777)	

## 10. Certificates and Protocols:

The unit complies to European directives and standards with European Directives and bears the CE marking. The unit is checked for tightness of the installed filters and a leak test certificate is issued. The HEPA filter has an individual test certificate which is included in the Air Cleaner's accompanying documents or supplied with each replacement HEPA filter.



### Manufacturer's Declaration of Conformity

The AAF AstroPure Air Cleaners are manufactured in compliance with applicable international regulations and standards by:

AAF Lufttechnik GmbH  
 Odenwaldstrasse 4  
 D-64646 Heppenheim  
 Germany  
 Telefon: +49 (0)6252 69977-0  
 Email: Sales.DACH@aaf-europe.com

A risk assessment and compliance evaluation procedure has been conducted referenced on the following certification procedures according to the assessment as in:

Machine directive 2006/42/EC, Directive on eco design EC 2009/125.

Following standards and guidelines were used for the assessment of the equipment's compliance:

Following standards and guidelines were used for the assessment of the equipment's compliance:

2006/42/EC	Machine Directive
2014/30/EC	Electromagnetic Compatibility (EMC) Directive
2014/35/EC	Low Voltage Directive (LVD)
2009/125/EC	ERP Energy conservation
1253/2014EC	ERP implementation, 2018
EN ISO 12100	General principles for design - Risk assessment and fire reduction
EN ISO 13857	Safety of machinery - Safety distances to prevent hazard zones being reached by upper and lower limbs
DIN EN 60335-1	Safety of electrical devices for household use and similar purposes - Part 1: General requirements
VDI 6022-2018	Hygiene requirements for ventilation and air-conditioning systems and units - Design and construction and materials

The AAF AstroPure Air Cleaner are in full compliance with the above mentioned directives, standards and guidelines. A technical documentation of the risk and the compliance assessment is available on request from the manufacturer.  
 Heppenheim, November 2020.

FAT Ruiter  
 Director Filtration technology

Heppenheim, November 2020



**DECLARATION OF CONFORMITY**

*This Declaration of Conformity is issued under the sole responsibility of the manufacturer*

**Manufacturer**

Company name: AAF International  
European Headquarters  
Full address: Odenwaldstraße 4  
D-64646 Heppenheim  
Country: Germany

**UK Authorised Representative**

*Which is established in the United Kingdom and has access to the Technical File*

Company name: Air Filters Ltd  
Full address: Bassington Lane  
Postal code: NE23 8AF  
Place: Cramlington, Northumberland  
Country: United Kingdom

**Object of the declaration**

Product: AstroPure 2000  
Function: Air Cleaner

**The object of the declaration described above is in conformity with the relevant UK Statutory Instruments (and their amendments)**

2008 No. 1597 Supply of Machinery (Safety) Regulations 2008  
2016 No. 1101 Electrical Equipment (Safety) Regulations 2016  
2016 No. 1091 Electromagnetic Compatibility Regulations 2016  
2012 No. 3032 The Restriction of the Use of Certain Hazardous Substances in Electrical and Electronic Equipment Regulations 2012

*References to the relevant designated standards used or references to the other technical specifications in relation to which conformity is declared:*

*BS EN ISO 12100:2010; BS EN ISO 13857:2019; BS STN EN 60204-1; VDI 6022-2018*

**Technical documentation for the product is available from:**

Name: Air Filters Ltd  
Full address: Bassington Lane  
NE23 8AF  
Cramlington, Northumberland  
United Kingdom

Signed for and on behalf of:

Place of issue: Amsterdam, The Netherlands  
Date of issue: April 6, 2021  
Name: Peter Ruiters  
Function: Director of Filtration Technology  
Signature: 

# Appendix

## LCD Control

Scheme for AP-2000 LCD screen  
With ZIEHL-ABEGG FAN (UV Lamp option)

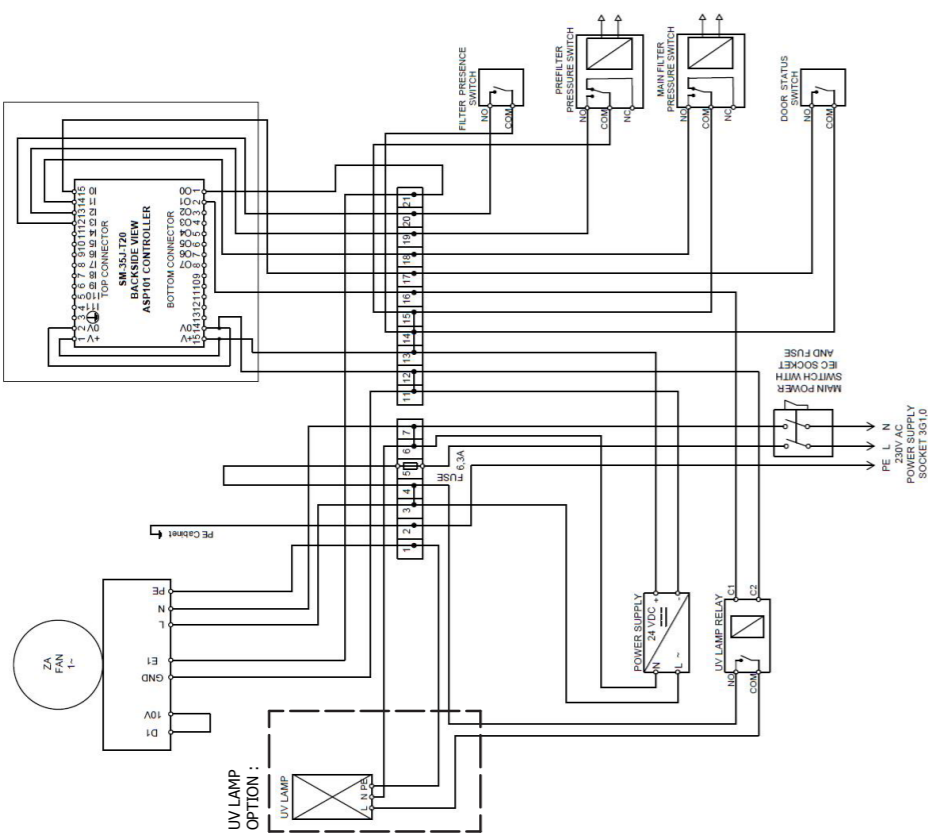

Scheme for AP-2000 LCD Screen  
With EBM PAPTST FAN (UV Lamp option)

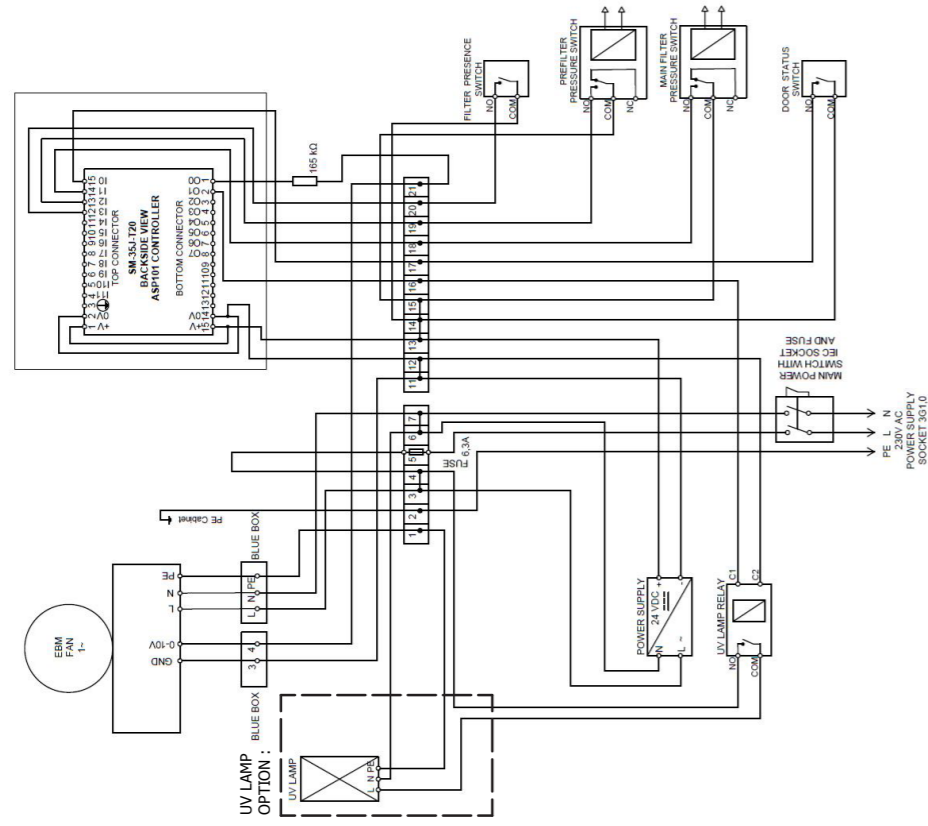

TITLE: AstroPure 2000 wiring diagram LCD Screen (+UV Lamp option)

DO NOT SCALE DRAWING	PRODUCT OWNER: AAF	PK: □	UL: □
DATE: 19/03/2021	DRAWN BY: Guillaume Fogeron		
SCALE: 1:1	APPROVED: Yvan Flourey		
PROJECT: 2020001D	UNIT: mm		
ARE UNCONTROLLED	REV: 1		
REF: AAF International	Community		
A2	SHEET: 1 OF 1	P	LCC

## Potentiometer Control

Scheme for AP-2000 Potentiometer  
with ZIEHL-ABEGG FAN

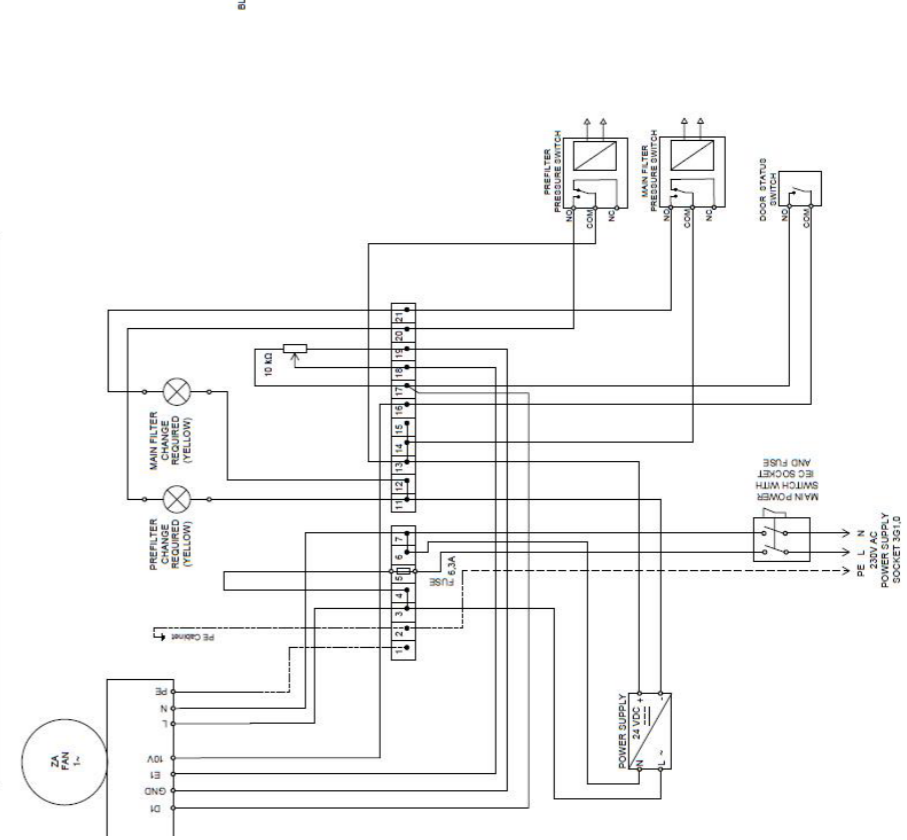

Scheme for AP-2000 Potentiometer  
with EBM PAPTST FAN

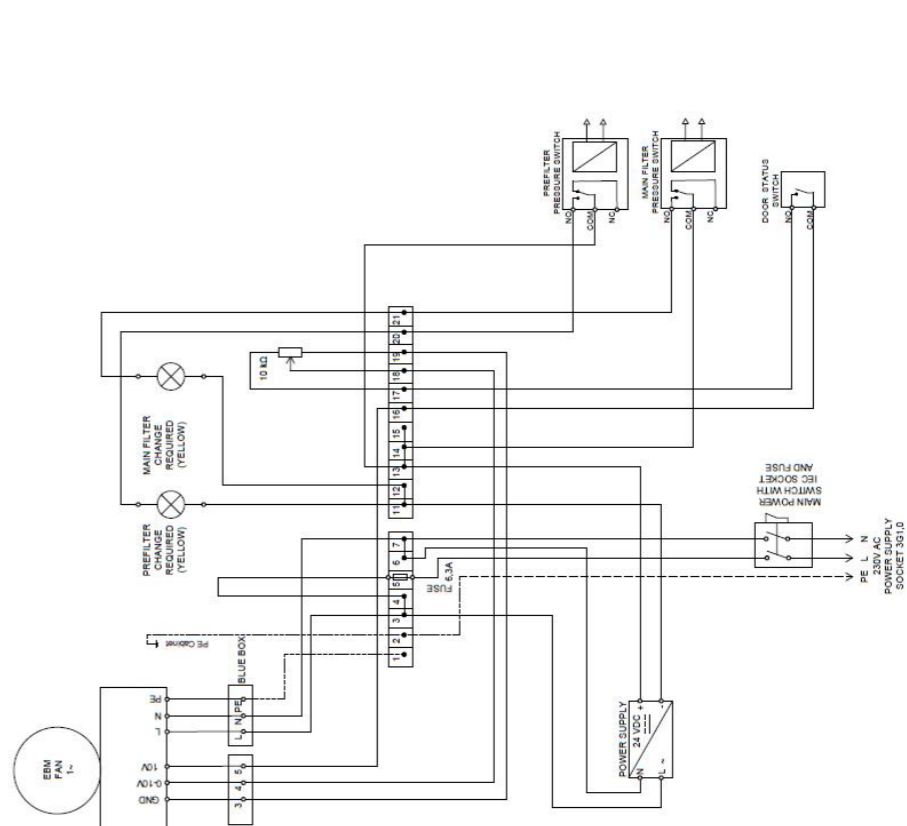

TITLE: AstroPure 2000 wiring diagram potentiometer

DO NOT SCALE DRAWING	PRODUCT OWNER: AAF	PK: □	UL: □
DATE: 19/03/2021	DRAWN BY: Guillaume Fogeron		
SCALE: 1:1	APPROVED: Yvan Flourey		
PROJECT: 2020001D	UNIT: mm		
ARE UNCONTROLLED	REV: 1		
REF: AAF International	Community		
A2	SHEET: 1 OF 1	P	POT

---

Notes

Notes

# AAF Sales Offices

## Dinair Finland

Dinair Clean Air, Oy  
Koivuvaarankuja 2,  
01640 Vantaa  
Phone: +358 10 3222610  
E-mail: cleanair@dinair.fi

## France

AAF S.A.  
9, Avenue de Paris  
94300 Vincennes  
Phone: +33 143 984 223  
Fax: +33 158 641 142  
E-mail: sales.france@aafeurope.com

## Germany & Austria

AAF-Lufttechnik GmbH  
Odenwaldstrasse 4  
64646 Heppenheim  
Phone: +49 (0)6252 69977-0  
E-mail: sales.DACH@aafeurope.com

## Dinair Latvia

Dinair Filton SIA  
Rupnicu Street 4  
Olaine, Latvia, LV-2114  
Phone: +371 67069823

## Dinair Denmark

AAF/Dinair APS  
Vallensbækvej 63.1  
2625 Vallensbæk  
Phone: +45 70260166  
E-mail: sales.denmark@aafeurope.com

## Great Britain and Ireland

Air Filters Ltd (AAF International)  
Bassington Lane, Cramlington  
Northumberland NE23 8AF  
Phone: +44 1670 591 790  
Fax: +44 1670 590 262  
E-mail: airfilter@aafeurope.com

## Greece

AAF-Environmental Control Epe  
1 Ifaistou & Kikladon  
15354 Glika Nera  
Phone: +30 210 663 20 15  
Fax: +30 210 663 51 09  
E-mail: greece@aafeurope.com

## Italy

AAF S.r.l.  
Via Friuli, 28/30  
21047, Saronno (VA)  
Phone: +39 02.9624096  
Fax: +39 02.9606409  
E-mail: sales.italy@aafeurope.com

## Dinair Norway

Dinair AS  
Prof Birkelands vei 36  
1081 Oslo  
Phone: +47 22 90 59 00  
Fax: +47 22 90 59 09

## Slovakia & Eastern Europe

AAF International s.r.o.  
Bratislavská 517  
91105, Trenčín, Slovakia  
Phone: +421 32/746 17 14  
www.aafintl.com

## Spain & Portugal

AAF S.A.  
Vidrieros, 10  
28830 San Fernando de Henares  
Madrid, Spain  
Phone: +34 916 624 866  
Fax: +34 916 624 275  
E-mail: info@aaf.es

## Dinair Sweden

Dinair AB  
Hamngatan 5  
SE-592 30 Vadstena  
Phone: +46 (0)143-125 80  
Fax: +46 (0)143-125 81

## The Netherlands

AAF Verkoop Nederland  
Boerdijk 29A  
7844 TB Veenoord  
Phone: +31 (0)591 66 44 66  
E-mail: aaf.verkoop@aafeurope.com



AAF International  
European Headquarters  
Odenwaldstrasse 4, 64646 Heppenheim  
Tel: +49 (0)6252 69977-0  
aafintl.com

AAF International B.V. has a policy of continuous product research and improvement and reserves the right to change design and specifications without notice.

©2019 AAF International and its affiliated companies.  
IM\_102\_EN\_122020